

Nº	Referencia	Descripción	Material	Cant.
1	17124053	RACOR	F-111	2
KIT TOMA CALEFACCION				
BOILER KIT				
MATERIAL ACABADO TRATAMIENTO PRESENTACION ESCALA				
DIBUJADO VERIFICADO GRADO PRECISION FECHA CREACION ULTIMA REVISION				
X.MARGARIT S. UBACH MEDIO 10/01/2014 ---				
		SOLÉ, S.A.	17211150	

Medidas Nominales (mm)

100	±0.2
30	±0.15
6	±0.1
0	±0.05
Fino	±0.1
Medio	±0.2
Basto	±0.5

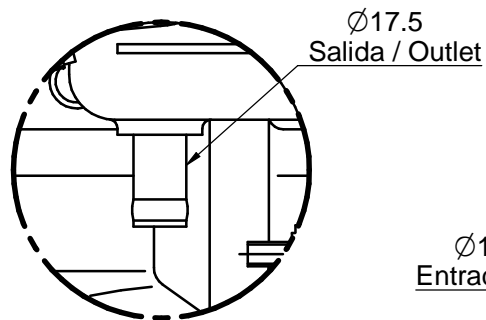
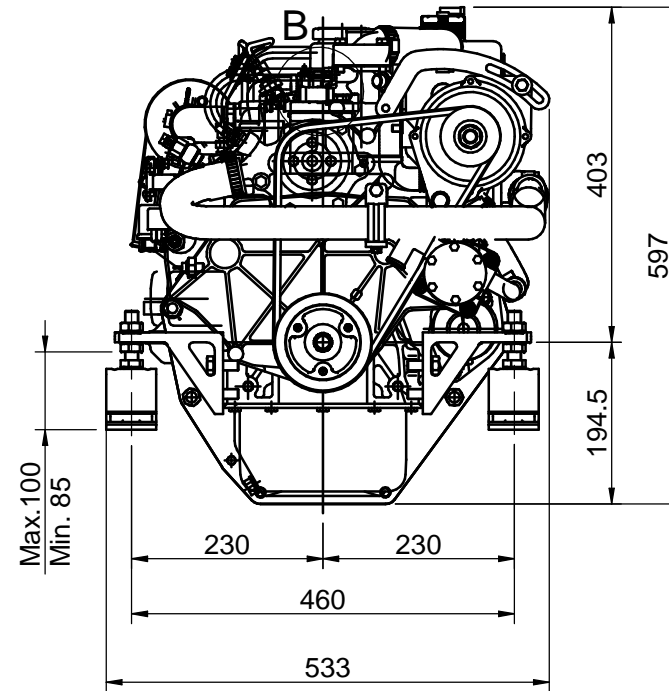
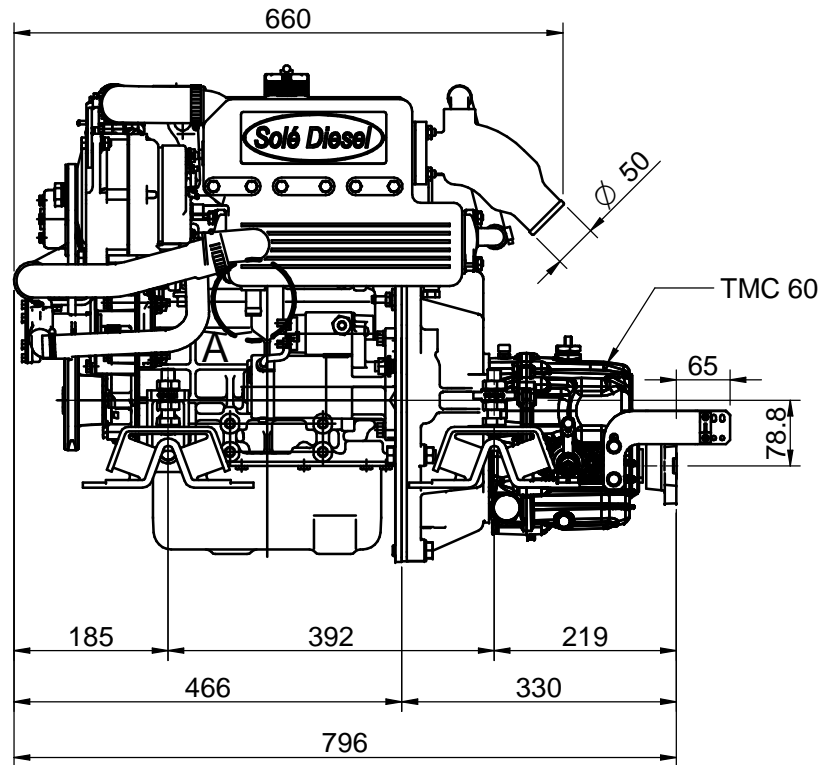

DETALLE A

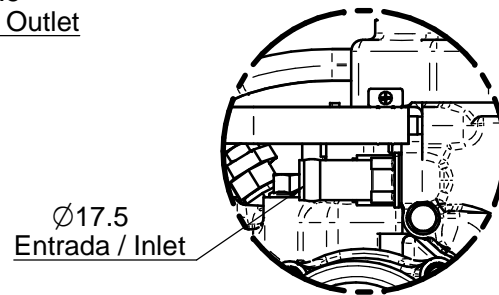

DETALLE B

DATOS TÉCNICOS / TECHNICAL DATA

- (1) Manguera agua salada/ Sea water hose: Ø20mm
- (2) Manguera entrada combustible / Fuel hose intake: Ø8mm
- (3) Manguera retorno combustible / Diesel Fuel return hose: Ø5mm

Medidas Nominales (mm)		100	MINI 33 CON KIT TOMA CALEFACCION			
	a	300	MINI 33 WITH BOILER KIT			
6	a	30	MATERIAL	ACABADO	TRATAMIENTO	PRESENTACION
						./.
0	a	6	DIBUJADO	VERIFICADO	GRADO PRECISION	FECHA CREACION
			X.MARGARIT	S. UBACH	MEDIO	10/01/2014
						ULTIMA REVISION

Grado de Precisión DIN-7168	Fino	±0.05			SOLÉ, S.A.	17211150_MI33
	Medio	±0.1				
	Bastio	±0.2				

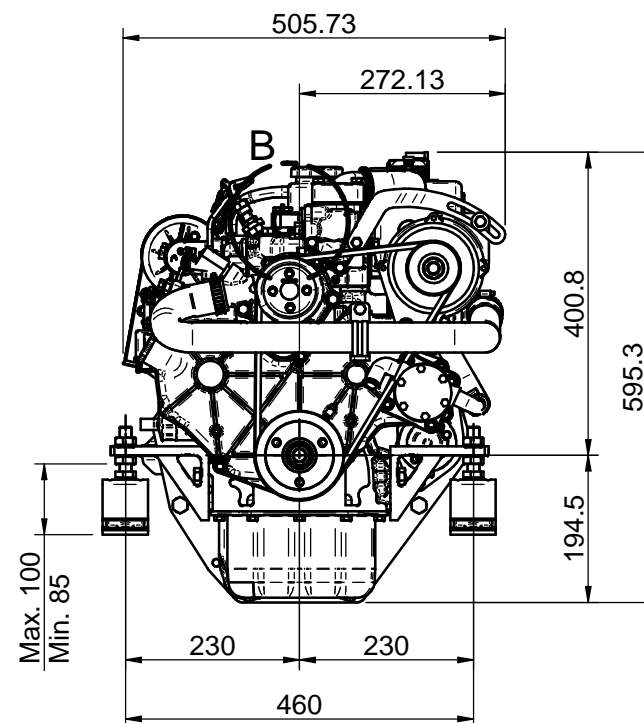
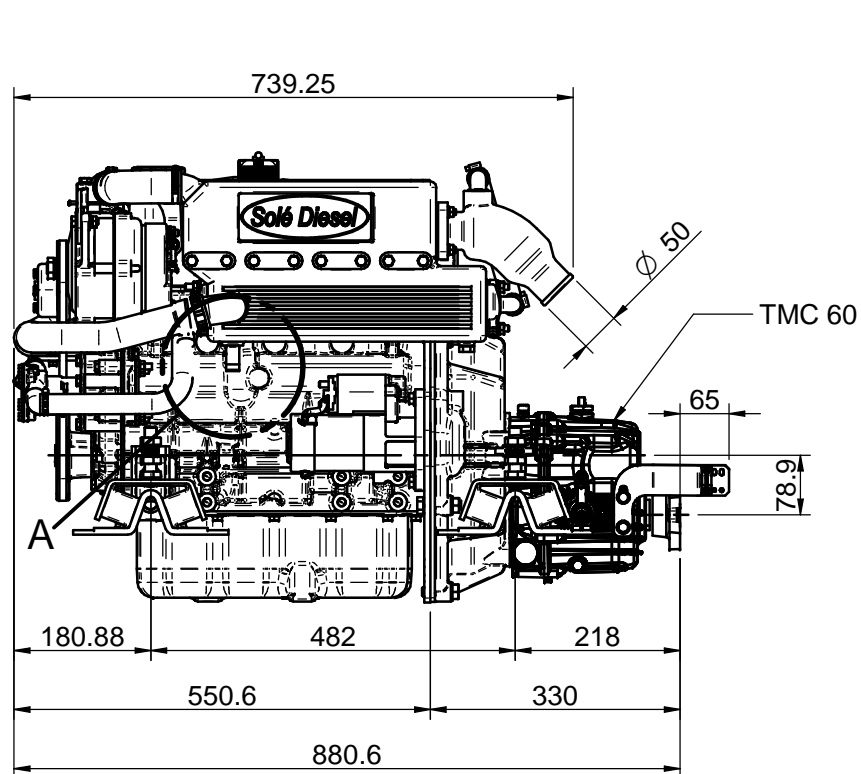

Detalle/Detail A

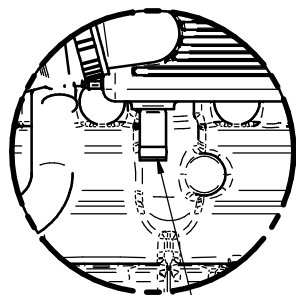

Entrada/Inlet
Ø 17,5

Detalle/Detail B

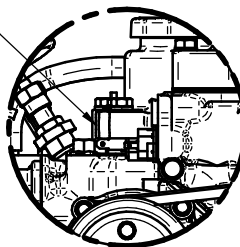

Salida/Outlet
Ø 17,5

DATOS TÉCNICOS / TECHNICAL DATA

- Manguera agua salada / Sea water hose: Ø20mm
- Manguera entarda combustible / Fuel hose Intake: Ø8mm
- Manguera retorno combustible / Fuel hose Return: Ø5mm

MINI 44 CON KIT TOMA CALEFACCIÓN

MINI 44 WITH BOILER KIT

MATERIAL	ACABADO	TRATAMIENTO	PRESENTACIÓN	ESCALA
DIBUJADO	VERIFICADO	GRADO PRECISIÓN	FECHA CREACIÓN	ÚLTIMA REVISIÓN
J.RODRÍGUEZ	S. UBACH		08/10/2015	---



SOLÉ, S.A.

17211150_MI44

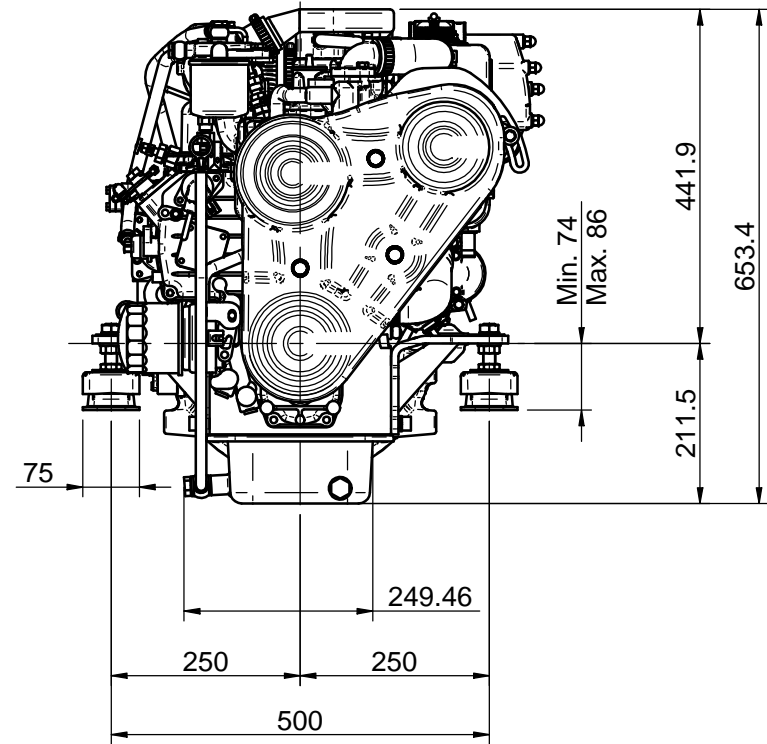
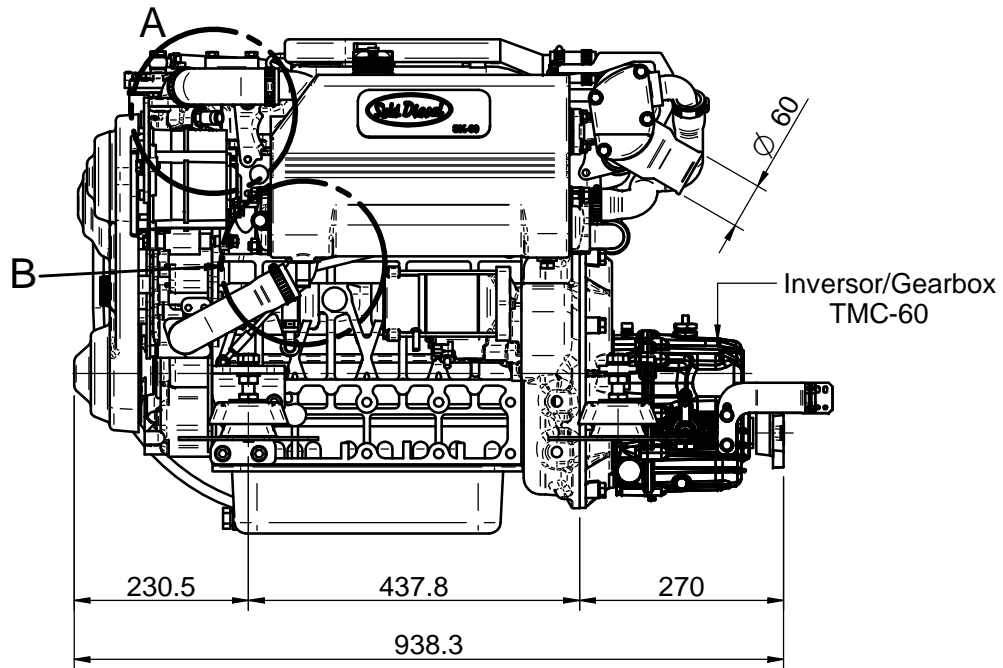

Detalle/Detail A

Detalle/Detail B

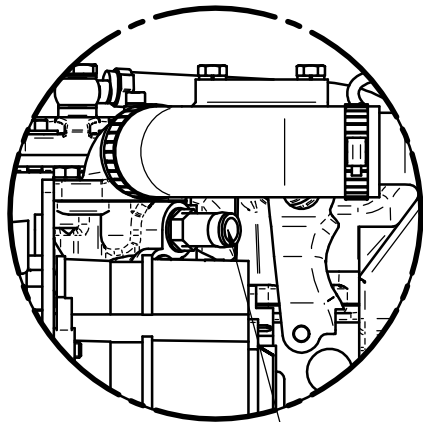

Entrada/Inlet
Ø17,5mm

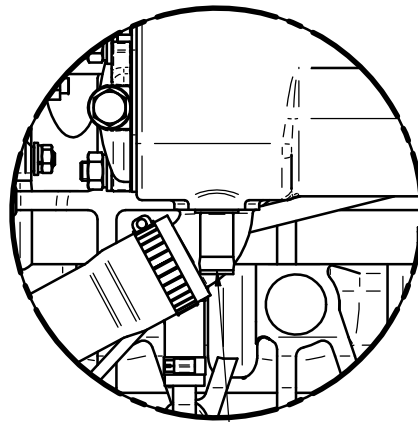

Salida/Outlet
Ø17,5mm

DATOS TÉCNICOS / TECHNICAL DATA

Manguera agua salada/ Sea water hose: Ø32mm
 Manguera entrada combustible / Fuel hose intake: Ø8mm
 Manguera retorno combustible / Diesel Fuel return hose: Ø5mm

MOTOR SK60 CON KIT CALEFACCIÓN

SK60 ENGINE WITH BOILER KIT

MATERIAL	ACABADO	TRATAMIENTO	PRESENTACIÓN	ESCALA
DIBUJADO	VERIFICADO	GRADO PRECISIÓN	FECHA CREACIÓN	ÚLTIMA REVISIÓN
J.RODRÍGUEZ			11/05/2017	---



SOLÉ, S.A.

17211150_SK60