

CORTE A-A

Nº	Referencia	Descripción	Material	Cant.
1	17210203	POLEA 3 CANALES, TIPO A	F-114	1
2	17210049	EJE TOMA DE FUERZA D40	F-114	1
3	53033010	ARANDELA GROWER Ø10 DIN-127	Acero	4
4	52203315	TORNILLO DIN-912 M10 x 60 x1.25	Acero 12.9	3
5	52102309	TORNILLO M10x30 DIN 933	Acero	1
6	60500064	ARANDELA TOPE Ø60/Ø10.5	F-112	1
7	40040086	CHAVETA 12x8, L= 45mm DIN-6885	Acero	1

Medidas Nominales (mm)	100	KIT EJE TOMA FUERZA D.40 Y POLEA 3A				
	30	KIT POWER TAKE-OFF SHAFT D40 & PULLEY 3A				
	6	MATERIAL	ACABADO	TRATAMIENTO	PRESENTACIÓN	ESCALA
	0	DIBUJADO	VERIFICADO	GRADO PRECISIÓN	FECHA CREACIÓN	ÚLTIMA REVISIÓN
Grado de Precisión DIN-7168	Fino ±0.05	X.MARGARIT	S. UBACH	MEDIO	08/04/2014	---
	Medio ±0.1			SOLÉ, S.A.	17210126	
	Basto ±0.2					

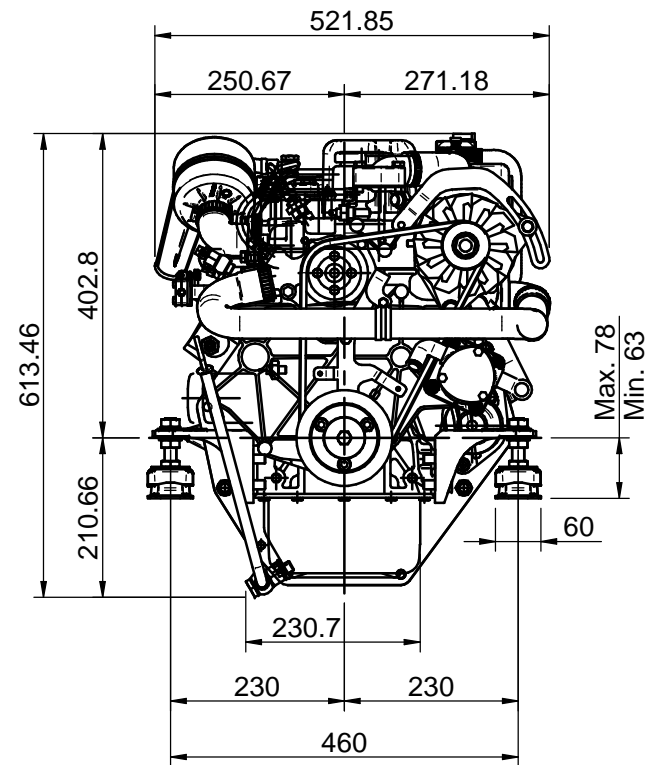
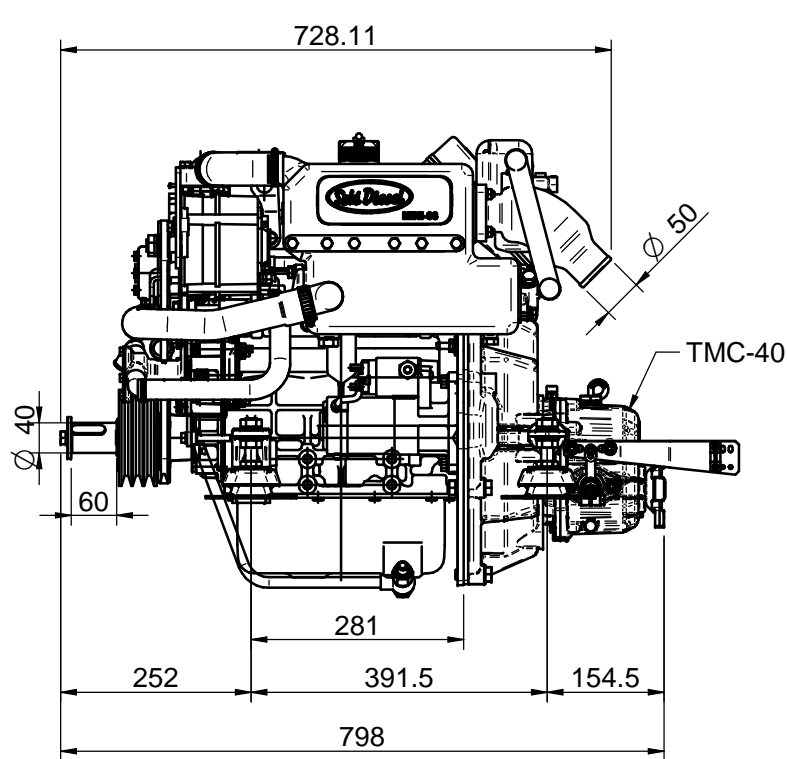

DATOS TÉCNICOS (TECHNICAL DATA)

Manguera agua salada (Sea water hose): Ø20mm
 Manguera entrada combustible (Fuel hose, inlet): Ø8mm
 Manguera retorno combustible (Fuel Hose, outlet): Ø5mm

Especificaciones del producto pueden ser modificadas sin previo aviso
 (Product specifications are subject to change without notice)

KIT EJE TOMA FUERZA D.40 Y POLEA 3A, MINI-33 v6

KIT PTO SHAFT D.40 & PULLEY 3A, MINI-33 v6 ENGINE

MATERIAL		ACABADO		TRATAMIENTO	PRESENTACIÓN	ESCALA
DIBUJADO		VERIFICADO	GRADO PRECISIÓN	FECHA CREACIÓN	ÚLTIMA REVISIÓN	
J.RODRÍGUEZ		P.IGLESIAS		13/06/2018	---	



SOLÉ, S.A.

17210126_MINI33v6

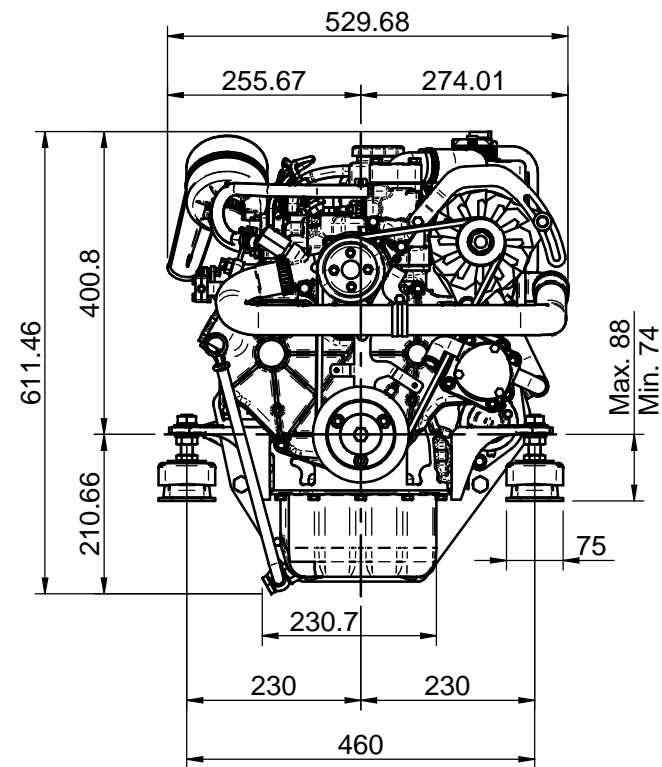
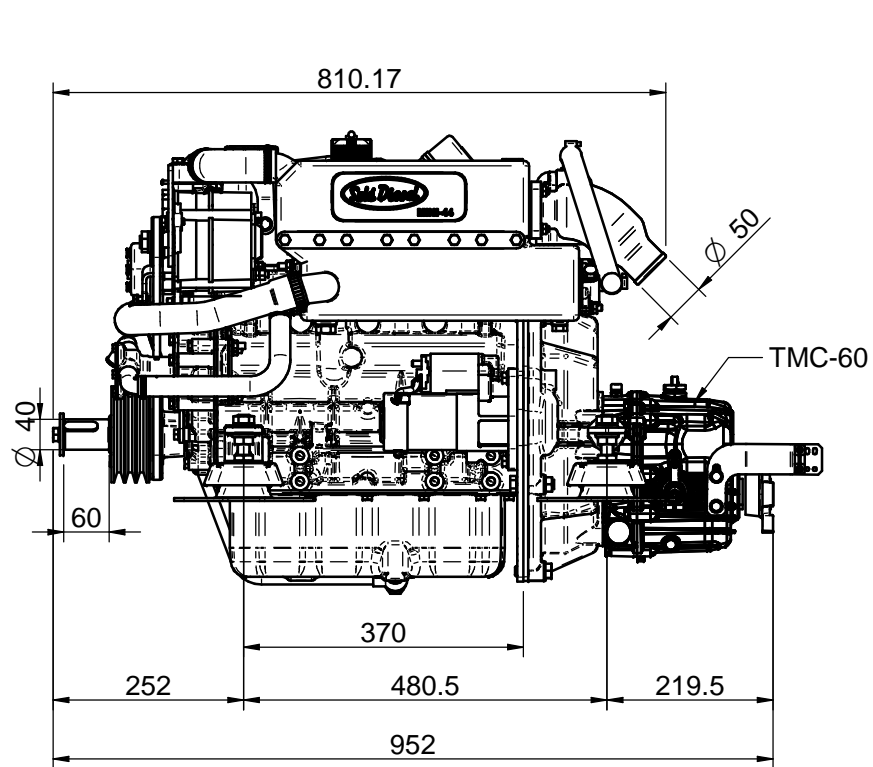

DATOS TÉCNICOS (TECHNICAL DATA)

Manguera agua salada (Sea water hose) : Ø20mm
 Manguera entrada combustible (Fuel hose, inlet) : Ø8mm
 Manguera retorno combustible (Fuel Hose, outlet) : Ø5mm

Especificaciones del producto pueden ser modificadas sin previo aviso
 (Product specifications are subject to change without notice)

KIT EJE TOMA FUERZA D.40 Y POLEA 3A, MINI-44 v6

KIT PTO SHAFT D.40 & PULLEY 3A, MINI-44 v6 ENGINE

MATERIAL	ACABADO	TRATAMIENTO	PRESENTACIÓN	ESCALA
DIBUJADO	VERIFICADO	GRADO PRECISIÓN	FECHA CREACIÓN	ÚLTIMA REVISIÓN
J.RODRÍGUEZ	P.IGLESIAS		13/06/2018	---



SOLE, S.A.

17210126_MINI44 v6

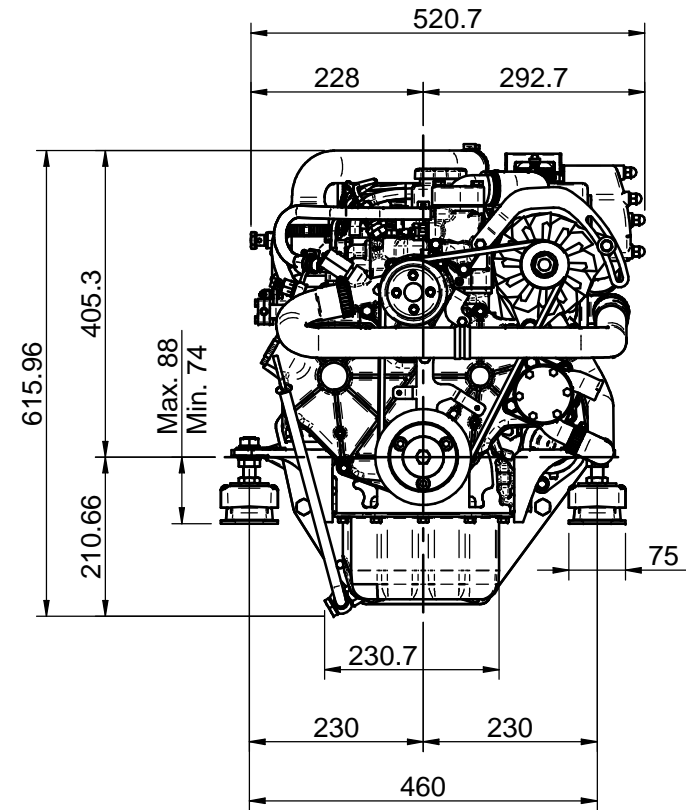
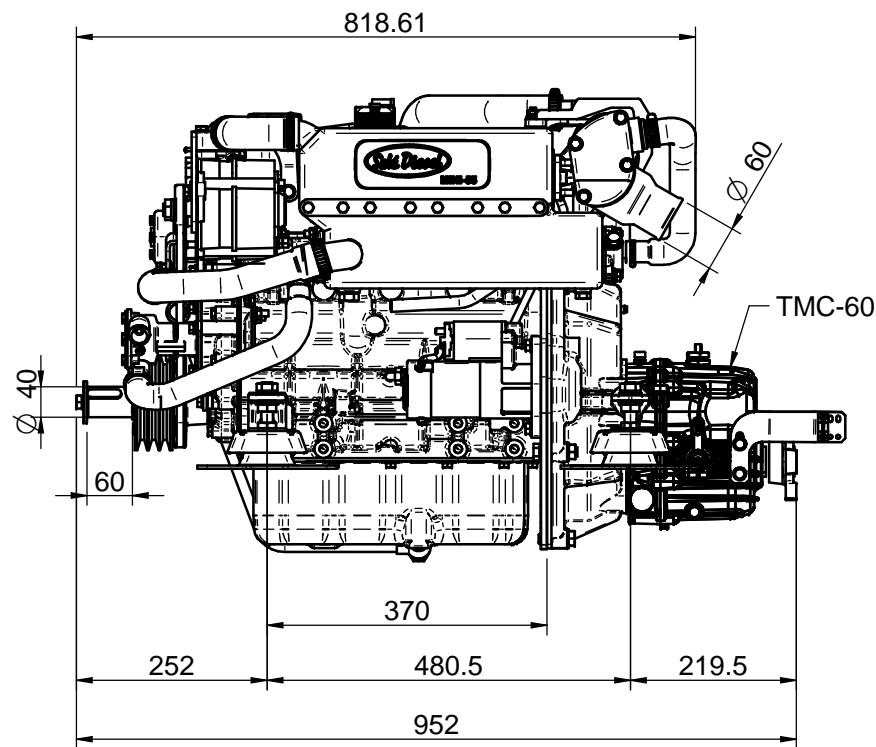

DATOS TÉCNICOS (TECHNICAL DATA)

- Manguera agua salada (Sea water hose): Ø26mm
- Manguera entrada combustible (Fuel hose, inlet): Ø8mm
- Manguera retorno combustible (Fuel Hose, outlet): Ø5mm

Especificaciones del producto pueden ser modificadas sin previo aviso
 (Product specifications are subject to change without notice)

KIT EJE TOMA FUERZA D.40 Y POLEA 3A, MINI-55 v6				
KIT PTO SHAFT D.40 & PULLEY 3A, MINI-55 v6 ENGINE				
MATERIAL	ACABADO	TRATAMIENTO	PRESENTACIÓN	ESCALA
DIBUJADO	VERIFICADO	GRADO PRECISIÓN	FECHA CREACIÓN	ÚLTIMA REVISIÓN
J.RODRÍGUEZ	P.IGLESIAS		13/06/2018	---
 SOLÉ, S.A.		17210126_MINI55v6		