

MARINE ENGINE

SDZ-165

4 cylinders in line 160 HP (m) (118 kW) 2300 RPM

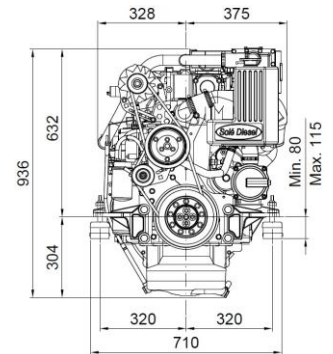
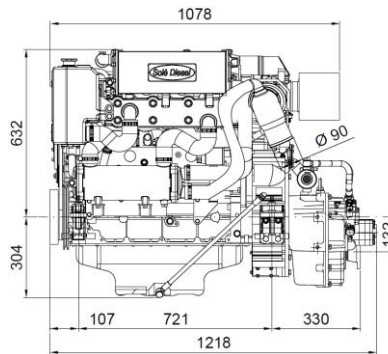

SDZ-165 24V Engine TM-170 2.04:1 Gbox.

Technical Specifications

Base engine manufacturer	Deutz
Type	Diesel, 4 stroke
Number of cylinders	4, in line
Intake system	Turbocharged with intercooler
Bore x Stroke	108 mm x 130 mm (4,25 in x 5,12 in)
Total displacement	4764 cc
Compression ratio	17,5:1
Intermittent power (ISO3046/1)	160 HP (m) (118 kW)
Continuous power	144,4 HP (m) (106,2 kW)
RPM	2300
Injection system	Mechanical and direct
Starter motor	24 V (4 kW)
Alternator	55 A (24 V)
Maximum operating angle	10°
Rotation (viewed from flywheel side)	Counterclockwise
Cooling system	Sea water heat exchanger and coolant closed circuit
Dry weight without gearbox	555 Kg (1223,6 lb)
Sea water hose diameter	42 mm (1,65 in)
Fuel feeding hose diameter	12 mm (0,47 in)
Fuel return hose diameter	12 mm (0,47 in)
Exhaust hose diameter	90 mm (3,54 in)
Certifications	-
Emission compliance	NON EMISSION

Performance Curves

Crankshaft torque

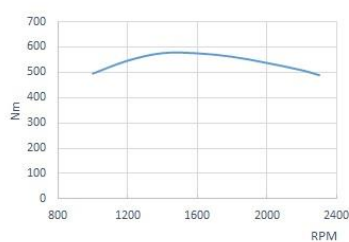

Power (ISO 3046/1)

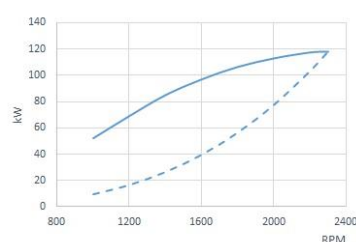

Fuel consumption

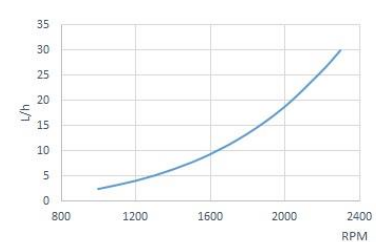

1 kW \cong 1,36 CV 1 kW \cong 1,36 HP (metric) 1 kW \cong 1,36 CH

Engine Power

Propeller Power

Panel



Panel SVT 30 Standard

Tachometer including hour meter

Coolant temperature gauge

Pre heating pilot light

Low battery alarm

High temperature alarm

Low oil pressure alarm

5 Positions key

Oil pressure gauge

Battery voltage indicator

Dimensions: 205 x 155 mm

Accessory

Scope of Supply

Instrument panel SVT 30

4 m electrical extension lead

Oil extraction pump

Owner's manual and spare parts manual

Optional Equipment

Twin instrument panel installation

Twin alternator

Earth isolated electrical system

Dry exhaust system

Keel cooling

Power takeoff shaft or pulley

Heater inlet

Drivetrain: propeller, shaft, sterntube

Water and fuel filters

Water, exhaust and diesel fuel hoses

Gearbox

Model	Type	Down angle	Reduction Ratio (Light Duty)	Reduction Ratio (Cont. Duty)	Engine Weight with Gearbox
DMT-100HL	Hydraulic	0°	-	5.95:1	830 Kg (1829 Lbs)
DMT-100IV	Hydraulic	14°	-	2.12:1	716 Kg (1578 Lbs)
TM-170	Hydraulic	0°	1.50:1-2.04:1-2.50:1-2.94:1	1.50:1-2.04:1	639 Kg (1408 Lbs)
TM-200B	Hydraulic	0°	-	3.60:1-4.48:1	802 Kg (1768 Lbs)
TM-265	Hydraulic	0°	2.09:1-2.82:1	2.09:1-2.82:1	731 Kg (1611 Lbs)
TM-265A	Hydraulic	7°	2.00:1-2.30:1	2.00:1	731 Kg (1611 Lbs)
TM-880A	Hydraulic	10°	1.53:1-2.08:1-2.60:1	1.53:1-2.08:1	618 Kg (1362 Lbs)
ZF 68 IV	Hydraulic	12°	1.56:1-2.00:1	-	626 Kg (1380 Lbs)

Authorized Dealer

www.solediesel.com

info@solediesel.com

Detailed drawings, brochures and manuals are available on the web solediesel.com. All rights reserved. Technical specifications, data and presentation are subjected to variations, changes and updates without prior notice. Non-contractual information.

