



MINI-33

Inboard Engine Base Mitsubishi

3 cylinders · 31,4 HP (23,1 kW) at 3.000 rpm



Technical Specifications

| | |
|------------------------------------|----------------------------------|
| Base | MITSUBISHI |
| Type | Diesel. 4 - Stroke Cycle |
| Number of Cylinders | 3 in line |
| Intake System | Naturally Aspirated |
| Bore and Stroke | 78 x 92 mm |
| Total Displacement | 1.318 cc |
| Compression Ratio | 22:1 |
| Intermittent Power (ISO 3046/1) | 31,4 HP (23,1 kW) |
| Continuous Power | 28,4 HP (20,9 kW) |
| Rated RPM | 3.000 |
| Combustion System | Indirect |
| Starter motor | 12 V (1,2 kW) |
| Alternator | 95 A |
| Engine. Max. Install. Angle | 30 intermittent. 15 Continuous. |
| Direction of Rotation (Crankshaft) | Anti Clockwise (View from Stern) |
| Cooling System | Heat Exchanger cooled |
| Dry Weight | 147 Kg |
| Water Hose (Inside Diameter) | 20 mm |
| Fuel Feed Hose (Inside Diameter) | 8 mm |
| Fuel Return Hose (Inside Diameter) | 5 mm |
| Exhaust hose (inside Diameter) | 50 mm |
| Certifications | EU RCD / EPA TIER III / BSO II |

Gearbox

| Model | TMC40P | TMC60 | TMC260 | TMC-60A | SPROP60 | TM345 | TM345A |
|------------------------------|-----------------|-----------------|--------------------------------|-----------------|------------|-----------------|-----------------|
| Type | Mechanical | Mechanical | Mechanical | Mechanical | Mechanical | Hydraulic | Hydraulic |
| Down Angle | - | - | - | 7° | - | - | 8° |
| Reduction Ratio (Pleasure) | 2,00:1 - 2,60:1 | 2,00:1 - 2,45:1 | - | 2,00:1 - 2,45:1 | 2,15:1 | 2,00:1 - 2,47:1 | 2,00:1 - 2,47:1 |
| Reduction Ratio (Cont. Duty) | 2,00:1 - 2,60:1 | 2,00:1 - 2,45:1 | 1,54:1; 2,00:1; 2,47:1; 2,88:1 | 2,00:1 - 2,45:1 | - | 2,00:1 - 2,47:1 | 2,00:1 - 2,47:1 |
| Engine Weight with Gearbox | 161 Kg | 167 Kg | 170 Kg | 170 Kg | 192 Kg | 197 Kg | 196 Kg |



www.solediesel.com

Detailed drawings, brochures and manuals are available on the web. © 2013. Solé Diesel. All rights reserved. Technical specifications, data and presentation are subjected to variations, changes and updates without prior notice. and without any obligation or liability whatsoever. Text and illustrations are not binding.

Performance Curves

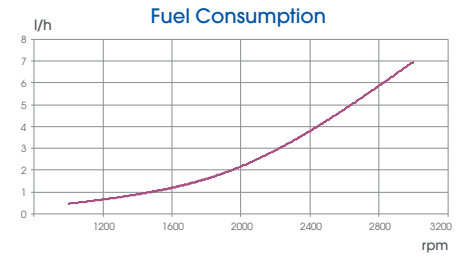
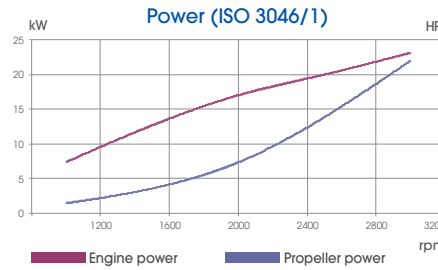
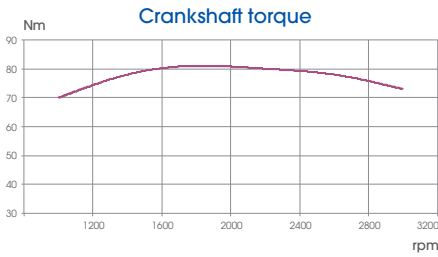

Instrument panel



Standard - TE2

- Tachometer
- Hour Meter
- Battery Warning Light
- Temperature Gauge
- Audible and visual alarm for low oil pressure and high engine temperature
- Key start / Stop
- Dimensions: 180 x 150 mm



Deluxe - TE3

- Tachometer
- Hour Meter
- Battery Warning Light
- Temperature Gauge
- Audible and visual alarm for low oil pressure and high engine temperature
- Voltmeter
- Oil Pressure Gauge
- Dimensions: 150 x 250 mm

Accessories

Standard Equipment

- Packaging
- Instrument Panel TE2
- 3m extension harness
- Anti Vibration Mounts
- Sump drain pump
- Owners manual

Optional Equipment

- We have a wide range of available accessories and kits.
- Our technical department will calculate the propeller to optimize your engine.
- For additional information access our website.

Dimensions

MNI-33 with TMC 40

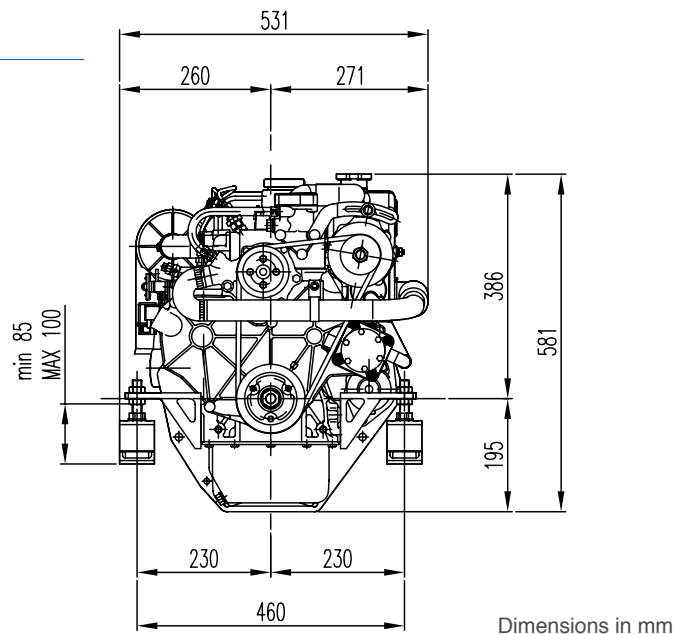
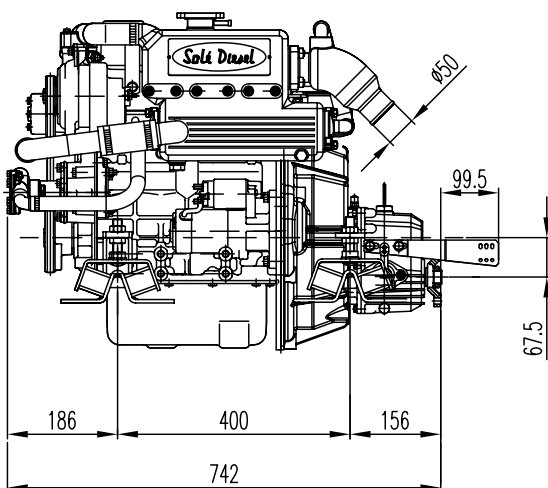

Authorized Dealer

Sole Diesel SOLÉ, S.A. C-243 b, km 2. 08760 Martorell. Barcelona.

Office tel. +34 93 775 14 00 - Fax +34 93 775 30 13

www.solediesel.com - info@solediesel.com

Detailed drawings, brochures and manuals are available on the web. © 2013. Solé Diesel. All rights reserved. Technical specifications, data and presentation are subjected to variations, changes and updates without prior notice. Text and illustrations are not binding.

